

**MOTOR SPECIFICATION SHEET**

MODEL : SF-QRGH 10HP 4P RATIO 1:15 (LT)

USED FOR : GEAR MOTOR

DESCRIPTION	DETAIL			
PHASE	3			
MODEL NAME	SF-QRGH			
RATED OUTPUT, HP (kW)	10 (7.5)			
POLE	4			
CODE	MEATH CODE : 1G7015-0750H-LTQR0			
OUTLINE DRAWING NO.	ONM24O346-A			
RATED VOLTAGE (V)	220	380	415	
RATED FREQUENCY (Hz)	50	50	50	
RATED CURRENT (A)	26.8	15.5	15.0	
RATED SPEED (min <sup>-1</sup> )	100	100	101	
RATED EFFICIENCY (%)	86.0	86.0	86.2	
EFFICIENCY CLASS	IE1			
THERMAL CLASS	155(F)			
RATING	S1 (CONTINUOUS)			
ENCLOSURE CONSTRUCTION	TOTALLY ENCLOSED FAN COOLED			
DEGREES OF PROTECTION	IP55			
METHOD OF COOLING	IC411			
FRAME NO.	132M			
WEIGHT (kg)	123			
STANDARD	IEC 60034-1, IEC 60034-30-1			
INSTALLATION	FOOT MOUNTED			
ROTATION	CCW (VIEWED FROM SHAFT END)			
BEARING	LOAD SIDE : 6310ZZ			
	OPPOSITE SIDE : 6207ZZ			
BEARING GREASE	UREA GREASE			
CIRCUMSTANCE CONDITION	AMBIENT TEMPERATURE : -20 ~ +40°C			
	AMBIENT HUMIDITY : 95%RH OR LESS			
	ABOVE SEA LEVEL : 1000m OR LESS			
	ENVIRONMENT : NO BURSTING/EROSIVE GAS OR VAPOR			
COLOR	MUNSELL N1.5 (BLACK)			
TERMINAL BOX	NO. OF LEAD WIRES : 6			
	SOURCE CONNECTION : TERMINAL BLOCK			
GEAR RATIO	1:15			
GEAR LUBRICANT	OIL (Must be filled by user.)			
SERVICE FACTOR	1.4			
MATERIAL	FRAME : STEEL PLATE			
	BRACKET (GEAR SIDE) : N/A (Frame is directly connected to Gear case)			
	BRACKET (OPP SIDE) : ALUMINIUM			
	GEAR CASE : CAST IRON			
	SHAFT (MOTOR) : STEEL			
	SHAFT (GEAR OUTPUT) : STEEL			
	STATOR CORE : ELECTRICAL STEEL			
	WIRE : ENAMELLED COPPER MAGNET WIRE			
	ROTOR CORE : ELECTRICAL STEEL			
	CONDUCTOR : ALUMINIUM			
	TERMINAL BOX : STEEL PLATE			
PAINTING : POLYURETHANE RESIN				
PRODUCTION COUNTRY	THAILAND			

Specifications subject to change without notice.

**SPECIFICATION SHEET NO.**

SS-M-2946-B

# MODEL SF-QRGH THREE PHASE INDUCTION MOTOR OUTLINE DRAWING

GEAR MOTOR

TOTALLY ENCLOSED FAN COOLED

DEGREES OF PROTECTION IP55

DUST & WATER JET PROOF

CUSTOMER \_\_\_\_\_

USER \_\_\_\_\_

FOR \_\_\_\_\_

CUSTOMER'S

ORDER NO. \_\_\_\_\_

QUANTITY \_\_\_\_\_

MFG.

ORDER NO. \_\_\_\_\_

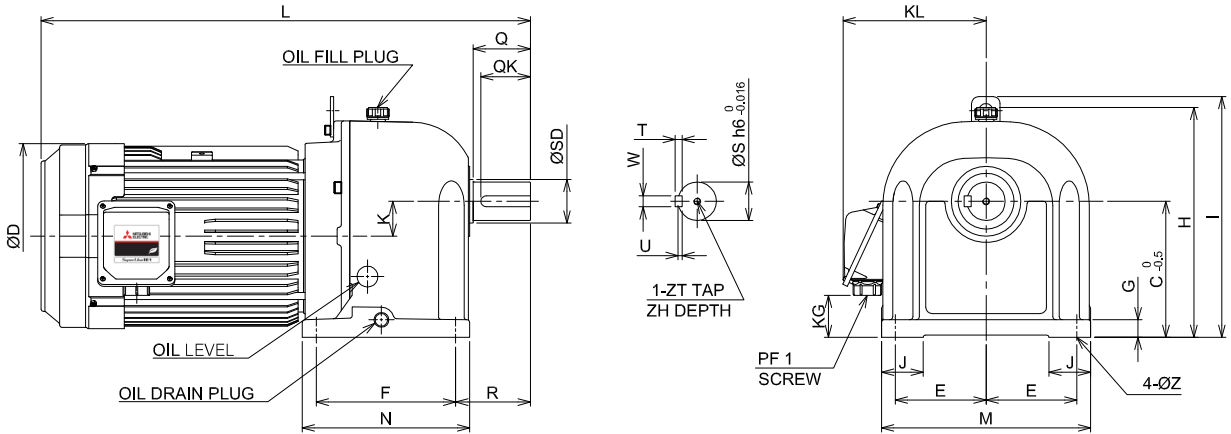

YOUR ORDER	GEAR RATIO	DIMENSION(mm.)																				WEIGHT (kg.)					
		L	Q	QK	ØD	K	F	R	N	T	W	U	ZT	ZH	ØS	ØSD	KL	KG	J	E	M		G	C	H	I	ØZ
	1:3~1:20	701.5	82	71	266	50	200	107	240	10	16	6	M10	18	55	58	205	77	60	130	300	25	195	330	345	19	123
	1:25,1:30	720	90	72	266	60	230	120	280	11	18	7	M10	18	60	63	205	102	70	150	350	30	230	380	395	24	144

YOUR ORDER	MOTOR FRAME SIZE	RATING	TH. CLASS	AMB. TEMP	BEARINGS		COLOR	GEAR RATIO	DIRECTION OF ROTATION (VIEWED FROM SHAFT END)	NO. OF LEAD WIRES	REMARKS
					LOAD SIDE	OPP. SIDE					
	132M	S1 (CONT.)	155(F)	40°C	6310ZZ	6207ZZ	BLACK (MUNSELL N1.5)	1:3~1:30	CCW	6	

YOUR ORDER	RATIO	SERVICE FACTOR	MOTOR OUTPUT		POLE	VOLT	HERTZ	OUTPUT SPEED (min <sup>-1</sup> )	AMP.	IE CODE - RATED EFF.	TYPE	LUBRICATION TYPE
			HP	kW								
	1:3	1.4	10	7.5	4	220/380/415	50	505/505/510	26.8/15.5/15.0	IE1 - 86.0%/86.0%/86.2%	LT	OIL <sup>(1)</sup>
	1:5	1.4	10	7.5	4	220/380/415	50	290/290/290				
	1:10	1.4	10	7.5	4	220/380/415	50	145/145/146				
	1:15	1.4	10	7.5	4	220/380/415	50	100/100/101				
	1:20	1.4	10	7.5	4	220/380/415	50	72/72/72.5				
	1:25	1.4	10	7.5	4	220/380/415	50	59/59/59.5				
	1:30	1.4	10	7.5	4	220/380/415	50	52/52/52.5				
	1:3	1.4	10	7.5	4	380/415	50	505/510	15.4/14.7	IE1 - 86.0%/86.7%	HT	
	1:5	1.4	10	7.5	4	380/415	50	290/290				
	1:10	1.4	10	7.5	4	380/415	50	145/146				
	1:15	1.4	10	7.5	4	380/415	50	100/101				
	1:20	1.4	10	7.5	4	380/415	50	72/72.5				
	1:25	1.4	10	7.5	4	380/415	50	59/59.5				
	1:30	1.4	10	7.5	4	380/415	50	52/52.5				

NOTE : (1) PLEASE FILL IN OIL BEFORE FIRST TIME USAGE. (SEE DETAIL IN THE INSTRUCTION MANUAL)

MITSUBISHI ELECTRIC AUTOMATION (THAILAND) CO.,LTD.

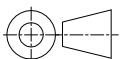

OUTLINE DRAWING NO.

REV.

DIMENSION IN mm.

SCALE : NTS

**ONM240346**

**A**